

PHASE THREE MODULAR

THREE STAGE MODULAR "SMART" CHARGING SYSTEM

INSTALLATION/OPERATION MANUAL

Case Models: PTMC-12X3, PTMC-24X3

Module Models: PTM-12-40, PTM-24-20

CONTENTS

<u>Section</u>	<u>Topic</u>	<u>Page</u>
I)	GENERAL INFORMATION	2
II)	IMPORTANT SAFETY INFORMATION	3
III)	BASIC INSTALLATION	5
	A) Configuration/Redundancy Notes	5
	B) Location	6
	C) Mounting	6
	D) d.c. Output Wiring	7
	E) a.c. Input Wiring	9
	F) Battery Type Selector Switch	11
	G) Module Installation/Removal	12
IV)	INSTALLATION OPTIONS	13
	A) Remote Monitor Panel	13
	B) Temperature Compensation	13
	C) Equalize Timer	14
	D) Remote Alarms	15
V)	OPERATION	16
	A) Three Stage Charge Regimen	16
	B) Time-Out Circuit	18
	C) PTMC Status/Control Panel	19
	D) Module Status Indicator	19
	D) Cooling Fan	20
VI)	APPLICATION NOTES	20
	A) Start-Up	20
	B) Constant Versus Occasional Use	20
	C) Proper Load Sizing	21
	D) Operation with Engine	21
	E) Operation as a d.c. Power Supply	21
VII)	SPECIFICATIONS	22
	A) PTM Module Specifications	22
	B) PTMC Case Specifications	22
VIII)	BATTERY CARE TIPS	24
IX)	REFERENCE APPENDIX	26

**M-PTMS-1
As of SEP 2004**



D) GENERAL OVERVIEW

The Phase Three Modular battery charger represents a new phase in charger design and performance. It provides three stage "smart" charging output, adapts for gel-cell or lead-acid batteries, features precise voltage compensation for varying battery temperature and is rated for continuous duty. The unique multiple slide-in architecture of the power circuits maximizes flexibility, reliability and serviceability of the system.

Following is a brief listing of some of the more important features/options of your Phase Three Modular (PTM Series) charger. Each is fully detailed later in this manual:

- **Three step "smart" charging: bulk, absorption, float**
- **Gel cell/lead-acid switch selects optimum charge/float voltages based on battery type**
- **Multiple output banks charge independently based on demand**
- **Multiple independent power modules enable scaling the system to meet output current requirements, and increase reliability—a failure of one module does not disable the system as a whole; remaining module(s) continue to provide a charging source. Modules can be quickly changed out without shutting the system down.**
- **Numerous module and system visual status indicators**
- **"Universal" input of 90-264V a.c., 50-60 Hz.—Can be used anywhere in the world**
- **Current limiting prevents damage from overload**
- **Cooling fan allows continuous operation at full-rated output**
- **High charge voltage time-out circuit prevents overcharge during continuous high amperage demand**
- **Optional temperature compensation sensor (model TCS-12/24) fine tunes output voltage based on battery temperature. Charging automatically ceases when over heated (50° C) battery is sensed.**
- **Optional remote panel (model PTM-RP) allows remote monitoring of charger status**
- **Optional equalization circuit connection**
- **Use as a power supply without in-line battery; allows continued use of d.c. powered electronics (when a.c. is available) in the event that batteries must be taken off line or removed.**
- **Rugged powder coated stainless steel case with drip shield**
- **UL Recognized and carries the CE mark.**

2



In addition, your Phase Three Modular Charger carries a full two year warranty against defects in materials or workmanship from the date of purchase. Easy module replacement minimizes inconvenience if repairs should be necessary. Careful attention to these instructions should help you to enjoy years of trouble-free service.

II) IMPORTANT SAFETY INSTRUCTIONS

1. **SAVE THESE INSTRUCTIONS** — This manual contains important safety and operating instructions for the Phase Three Modular Charger.
2. Before using this battery charger, read all instructions and cautionary markings on (1) the battery charger (2) the battery, and (3) any product powered by the battery.
3. **CAUTION** — To reduce the risk of injury, charge only 6 cell (using PTM-12-40 Modules) or 12 cell (using PTM-24-20 Modules) lead-acid rechargeable batteries (flooded, AGM, gel or sealed). Other types of batteries may burst, causing personal injury and damage.
4. Do not expose charger to rain or spray.
5. Use of an attachment not recommended or sold by NEWMAR may result in a risk of fire, electric shock or injury to persons.
6. To reduce the risk of damage to the electric plug and cord (if plugged into an a.c. outlet), pull by plug rather than cord when disconnecting the charger.
7. Make sure the cord is located so that it will not be stepped on, tripped over, or otherwise subjected to damage or stress.
8. An extension cord should not be used. Use of an improper cord could result in a risk of fire and electric shock.
9. Do not operate the charger with a damaged cord or plug; replace them immediately.
10. Do not operate the charger if it has received a sharp blow, been dropped, or otherwise damaged; take it to a qualified serviceman.
11. Do not disassemble the charger; take it to a qualified serviceman when service or repair is necessary. Incorrect reassembly may result in a risk of electric shock and fire.
12. To reduce the risk of electric shock, disconnect the charger from a.c. source before attempting any maintenance or cleaning.

WARNING—RISK OF EXPLOSIVE GASES

1. WORKING IN THE VICINITY OF A LEAD-ACID BATTERY IS DANGEROUS. BATTERIES GENERATE EXPLOSIVE GASES DURING NORMAL BATTERY OPERATION. FOR THIS REASON, IT IS OF UTMOST IMPORTANCE THAT BEFORE INSTALLING AND USING YOUR



ELECTRONIC POWER PRODUCTS
COMMUNICATION • NAVIGATION
www.newmarpower.com

3

**P.O. Box 1306
Newport Beach,
California 92663**

**Phone: 714-751-0488
Fax: 714-957-1621
E-Mail: sales@newmarpower.com**

CHARGER, YOU READ THIS MANUAL AND FOLLOW THE INSTRUCTIONS EXACTLY.

2. To reduce the risk of battery explosion, follow these instructions and those published by the battery manufacturer and by the manufacturer of any equipment you intend to use in the vicinity of the battery. Review all cautionary markings on these products.

PERSONAL PRECAUTIONS

1. Someone should be within range of your voice or close enough to come to your aid when you work near a lead-acid battery.
2. Have plenty of fresh water and soap nearby in case battery acid contacts skin, clothing or eyes.
3. Wear complete eye protection and clothing protection. Avoid touching your eyes while working near a battery.
4. If battery acid contacts skin or clothing, wash immediately with soap and water. If battery acid enters the eye, immediately flood the eye with running cold water for at least 10 minutes and get medical attention immediately.
5. NEVER smoke or allow a spark or flame in the vicinity of the battery or engine.
6. Be extra cautious to reduce the risk of dropping a metal tool onto the battery. It might spark or short-circuit the battery or other electrical part and cause an explosion.
7. Remove personal metal items such as rings, bracelets, necklaces and watches when working with a lead-acid battery. A lead-acid battery can produce a short-circuit current high enough to weld a ring or the like to metal, causing a severe burn.
8. Use the battery charger for charging gel-cell, AGM or flooded lead-acid batteries only. It is not intended to supply power to a low voltage electrical system other than in a starter-motor application. Do not use the charger for charging dry-cell batteries that are commonly used with home appliances. These batteries may burst and cause injury to persons and damage to property.
9. NEVER charge a frozen battery.

PREPARING TO CHARGE

1. Be sure the area around the battery is well ventilated.
2. Clean battery terminals. Be careful to keep corrosion from coming in contact with eyes.
3. Add distilled water in each cell until battery acid reaches level specified by battery manufacturer. This helps purge excessive gas from cells. Do not overfill. For a battery without cell caps, carefully follow manufacturer's recharging instructions.

4



4. Study all battery manufacturer's specific precautions such as removing or not removing cell caps while charging and recommended rates of charge.

GROUNDING AND a.c. POWER CORD CONNECTION

1. The charger should be grounded to reduce the risk of electric shock.

(For marine applications only) EXTERNAL CONNECTIONS TO THE CHARGER SHALL COMPLY WITH UL RECOMMENDATIONS AND/OR UNITED STATES COAST GUARD ELECTRICAL REGULATIONS (33CFR183, SUB-PART I)

(For marine applications only) THE INSTALLATION AND PROTECTION OF VESSEL WIRING ASSOCIATED WITH BATTERY CHARGERS SHALL COMPLY WITH ABYC STANDARDS; E-8) AC ELECTRICAL SYSTEMS ON BOATS, E-9) DC ELECTRICAL SYSTEMS ON BOATS, AND A-20) BATTERY CHARGING DEVICES.

III) BASIC INSTALLATION

A) Configuration/Redundancy Notes

The PTM Charger is supplied as two basic components; (a) the charger case (PTMC) with built-in controller and three charger bays and (b) up to three power modules (PTM). The typical system employs at least two modules, to provide redundancy. The modules should be removed from the case and set aside during installation and wiring of the case, then inserted into the PTMC to complete the installation. Any unused module bay should be covered with a blank panel. (One blank panel is supplied with the PTMC).

While the PTM Charger has both three module bays and three output banks, it is important for the installer and user to understand that this does not imply a correlation between Bay #1 and Bank #1, Bay #2 and Bank #2, etc. Rather, each individual bay feeds all three output banks. To illustrate:

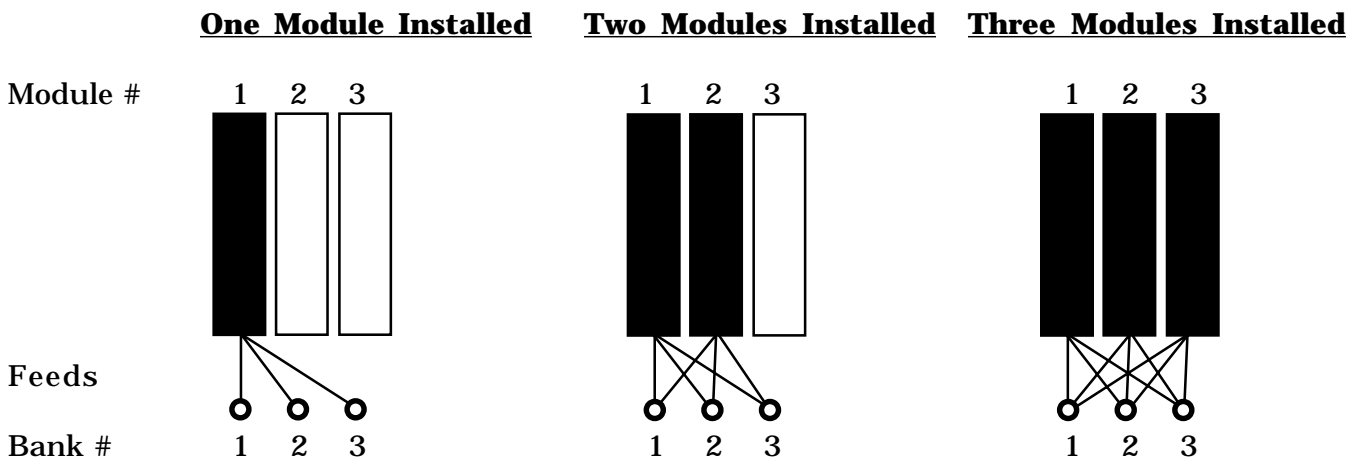

Note: All three output banks of each module are diode isolated from each other.



ELECTRONIC POWER PRODUCTS
 COMMUNICATION • NAVIGATION
www.newmarpower.com

This ensures that in the event one module fails or is removed, the remaining module(s) will continue to supply d.c. current to all three output banks.

What this also shows is that if the installation has, for instance, three independent battery banks it does not necessarily require three modules to be installed. Two may suffice, provided the total output current meets system requirements. However, the installer may choose to install an extra module to provide an added measure of reliability, or *redundancy*.

For example: If a 12 volt system requires 80 amps to meet charging needs and to supply the on-board d.c. equipment, then two PTM-12-40 modules would provide all the necessary current. But by installing a third module, the user is assured that in the event of a module failure, the remaining two will continue to fully supply the needed current until the failed module can be replaced. In addition, the 80 amp load is shared equally by all three modules, reducing the load on each, which contributes to longer module life.

B) Location

The charger should be mounted on a wall, bulkhead or other suitable mounting surface as close to the batteries to be charged as possible. Do not mount the charger directly over the batteries as battery fumes may cause excessive corrosion. **WARNING: The charger is not ignition protected so it must not be located in an area where ignition protected equipment is required.** The area should be well ventilated and free from excessive moisture, exhaust manifolds and battery fumes.

Vertical mounting is preferred. However, horizontal mounting is acceptable where absolutely necessary. *Do not mount the charger where water, spray or condensation can occur, as this will shorten charger life.* It should not be located where there is a possibility of dust or debris being drawn into the unit through the fan. A minimum of 2" clearance around the charger is recommended for proper cooling.

If the charger is located in an extreme heat area, such as an unventilated engine room, and maximum operating temperature is exceeded, an automatic thermal protection circuit will turn the charging modules off. They will automatically return to operation once a safe operating temperature is reached. However, if this over-temperature shut-down condition occurs repeatedly, the charger should be relocated to a cooler environment.

C) Mounting

Note: Setting of the battery type selector switch and installation of options such as equalization or alarms requires access to the control board compartment on the left side of the charger. If the charger is to be mounted where there is inadequate room to work on that side, then complete those steps prior to mounting. (Refer to the relevant sections of this manual for switch settings, page 11, and installation options, page 13.)

The charger may be mounted on either a metal or non-metal surface (see to chassis grounding note, following page). Mounting requires four screws (wood or machine screws,



depending on mounting surface) sized for 1/4" holes, plus two temporary holding screws. Note that, in addition to the four permanent mounting holes in the flanges, there is a hole in each mounting flange which is "keyhole" shaped. This is provided to ease vertical installation.

Make a mark on the wall or bulkhead where each of the keyhole slots will be located. Then drive a screw about halfway in at each of these marks. Hang the charger onto the bulkhead using the keyhole slots. Doing this will save you from having to support the charger's weight while you are driving in the four permanent mounting screws. Note: The keyhole slots may be used for additional support screws but they are not to be used as permanent mounting points by themselves.

**Per ABYC A-20: A d.c. chassis grounding conductor shall be connected from the case of the battery charger to the engine negative terminal or its bus, and must not be more than one size under that required for the d.c. current-carrying conductors, and not less than 16 AWG.*

IMPORTANT: Although the charger is constructed of materials and in a manner which makes it highly resistive to the corrosive effects of moisture in the environment, the charger is not water-resistant. Do not mount the charger where there is a possibility of water entering the unit. Evidence of water entry into the charger will void the warranty.

D) d.c. Output Wiring

Note: Only qualified service personnel should access the output terminals of the charger.

The installer must provide output wires and 5/16" ring lug connectors (for attaching wires to output terminals). Use the table below to determine the correct gauge wire, based on the total maximum output amps of the charger and the length of the wire run from the charger to the batteries.

Note: In order to avoid the possibility of undersized wiring in the event of future addition of modules, it is strongly recommended to use wires sufficiently sized for an installation with a fully populated PTMC Case. The chart below assumes this type of installation.

PTMC Model	Max. Output Amps	Length of Wire from Charger to Batteries (in feet)		
		10'	15'	20'
		Minimum Wire Gauge AWG (mm)		
PTMC-12X3	120	#1 (50mm)	#2/0 (70mm)	#3/0 (95mm)
PTMC-24X3	67	#6 (16mm)	#4 (25mm)	#2 (35mm)

**Based on N.E.C. Minimum Wire Size Chart and ABYC 3% Voltage Drop Chart*

ENSURE THAT LEADS ARE PROPERLY FUSED AT THE BATTERY. (REFER TO ABYC RECOMMENDATIONS.)

Important wiring note: The charger's control circuitry operates using voltage sensed from the #1 output terminal. Therefore, if the system has only one battery bank, it *must* be attached to the #1 terminal. Note also that this causes the "NO OUTPUT" indicator on the Status Panel to illuminate as soon as a battery is attached to the #1 terminal, even when there is no a.c. input. This is normal.

A note about the internal d.c. fuses: The internal wiring of each Phase Three charger module is protected against an internal short, or reverse polarity battery hook-up, by an internal d.c. fuse. The fuse is not user replaceable. If this fuse blows the unit must be returned to NEWMAR or a qualified electronic technician for repair.

Typical d.c. wiring configurations are illustrated in the following two diagrams.

Simple d.c. Wiring (Preferred Method)

Note: This diagram does not illustrate a complete system. Refer to ABYC Standards E-8) AC Electrical Systems on Boats, and E-9) DC Electrical Systems on Boats

*Per ABYC A-20: A d.c. chassis grounding conductor shall be connected from the case of the battery charger to the engine negative terminal or its bus, and must not be more than one size under that required for the d.c. current-carrying conductors, and not less than 16 AWG

A 1/4" X 20 grounding stud is located on the lower right hand side of the PTMC case.

Note: At least one battery must be connected to Bank # 1

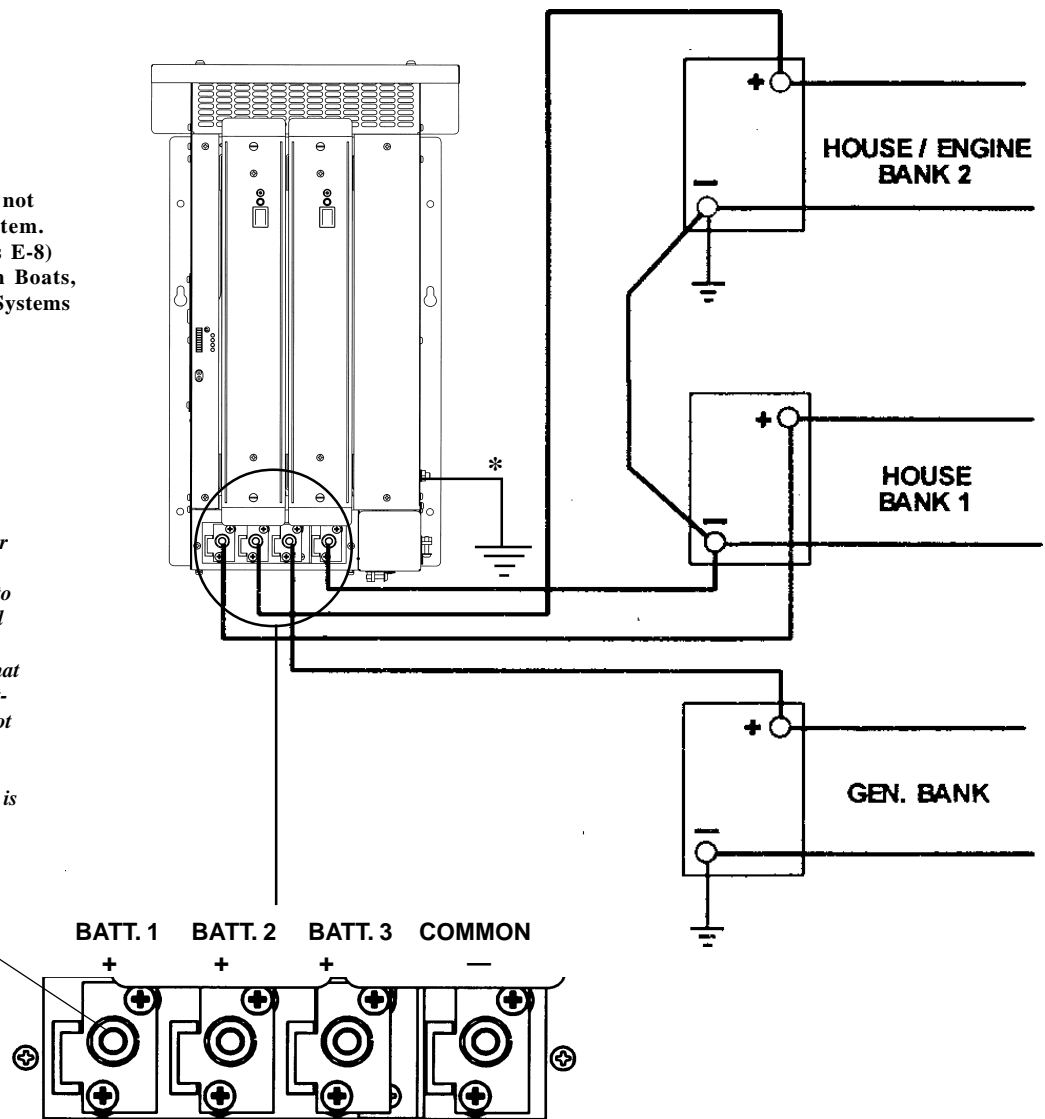

d.c. Wiring With Battery Switch

Note: This diagram does not illustrate a complete system. Refer to ABYC Standards E-8) AC Electrical Systems on Boats, and E-9) DC Electrical Systems on Boats

**Per ABYC A-20: A d.c. chassis grounding conductor shall be connected from the case of the battery charger to the engine negative terminal or its bus, and must not be more than one size under that required for the d.c. current-carrying conductors, and not less than 16 AWG*

A 1/4" X 20 grounding stud is located on the lower right hand side of the PTMC case.

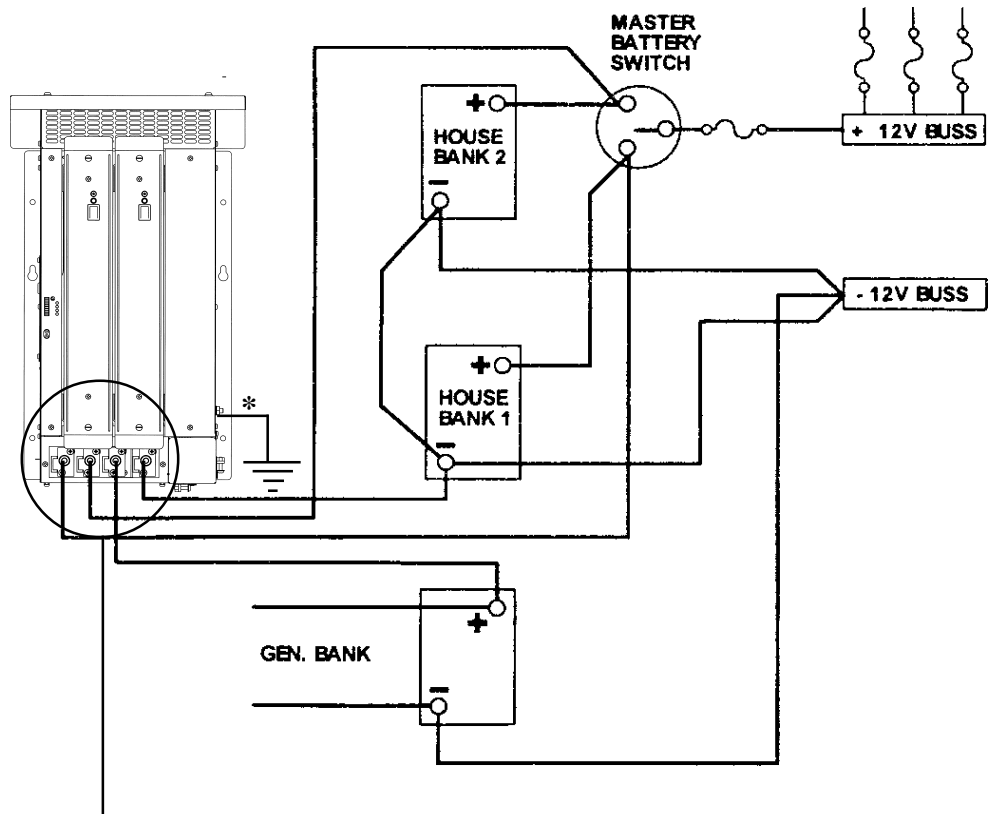

Note: At least one battery must be connected to Bank # 1

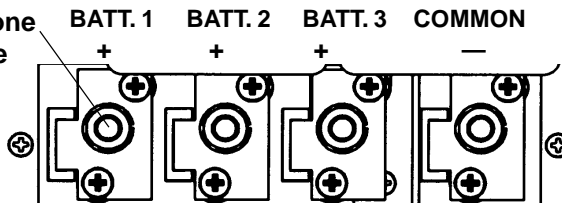

E) a.c. Input Wiring

The PTM Charger operates in a range of 90-264V a.c., 47-63 Hz. No changing of any switch settings is required for either 115V or 230V applications.

The charger is designed for hard-wiring directly to the vessel's a.c. distribution system. Recommended wire gauge for both case models is 12 AWG. Use stranded, not solid wire.

a.c. input for the charger must be routed through a separate dedicated fuse or circuit breaker on an a.c. distribution panel with proper safety/earth chassis ground



ELECTRONIC POWER PRODUCTS
COMMUNICATION • NAVIGATION
www.newmarpower.com

in accordance with all applicable local codes and ordinances. The recommended fuse or circuit breaker value for both case models is 25 amps for 115V applications and 15 amps for 230V applications.

To access the a.c. wiring compartment, loosen or remove the three screws securing the compartment cover as shown here:

a.c Wiring Compartment

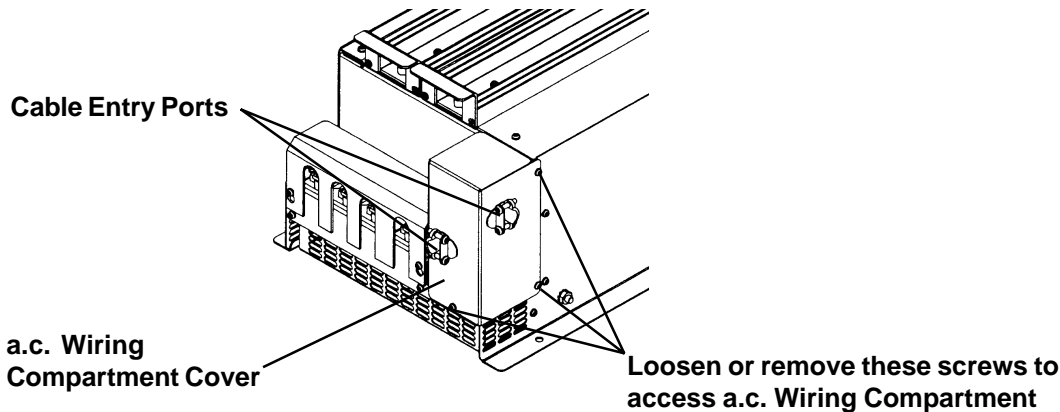

Two cable entry ports are provided. Use whichever port provides more convenient cable routing. Feed the a.c. cable through the port then attach the individual wires as shown in the diagram below.

a.c. Input Wiring (as viewed from bottom of charger)

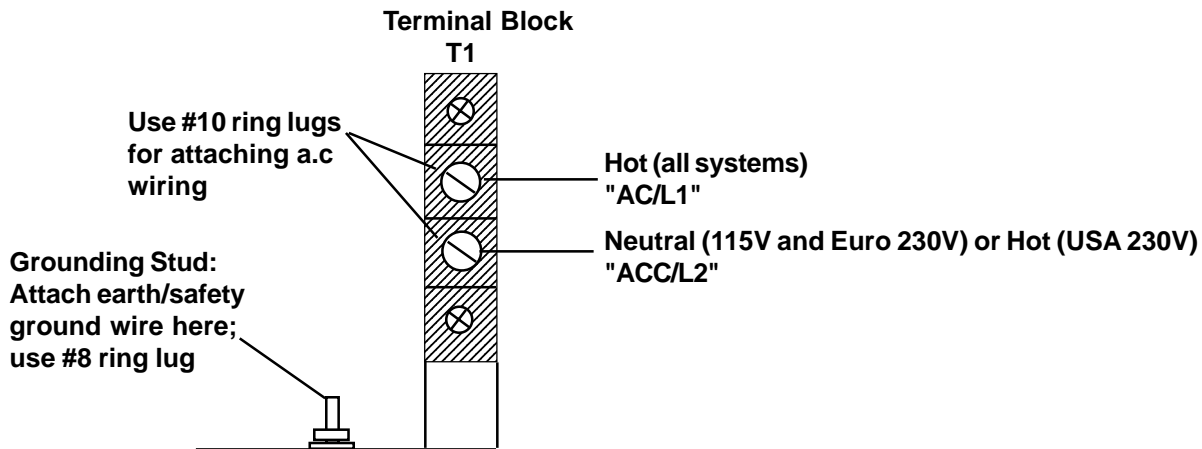

Note: In USA 230V four-wire systems, the neutral wire is unused and should be safely capped off.

CAUTION (230 V a.c applications only): If a.c. input is derived from a source consisting of two HOT leads (phase-to-phase 230V a.c. input voltage), an external fuse or circuit breaker must be used to protect the unfused (formerly NEUTRAL, now HOT) lead.

After wiring is completed, replace the compartment cover, then securely tighten the entry port cable strain relief.

A note about the a.c. input fuses: The a.c. input to each PTM Module is protected by an input fuse which is located inside the unit. Due to the current limiting characteristic of the charger, it is highly unlikely that this fuse will blow unless there is some other malfunction within the charger. This fuse is not user-replaceable. Replacement of the input fuse must be performed by a qualified service person.

(In marine applications) All charger wiring should be installed in accordance with UL, U.S. Coast Guard and/or A.B.Y.C. regulations and recommendations, as well as all relevant local codes. See REFERENCE APPENDIX at the end of this manual for sources.

F) Battery Type Selector Switch Setting

1) Gel/Lead-Acid Selector Switch Purpose

According to battery manufacturers, the ideal charge regimen for gel-cell and wet or flooded lead acid batteries differs somewhat.

The gelled electrolyte in a sealed battery may be lost or damaged by high voltage and, once lost, cannot be replaced as it can with a wet lead acid battery. Manufacturers of gel-cells usually recommend an ideal charge voltage which is slightly lower for a gel-cell than a lead acid battery.

However, when the charger is in the float voltage mode over lengthier periods of time, gelled electrolyte in a sealed battery is not susceptible to evaporation, as is the non-immobilized electrolyte of a wet lead acid battery. This evaporation can be accelerated by the applied voltage. Consequently, the ideal float voltage is slightly higher for a gel-cell than a lead acid battery.

Some batteries are available which do not conform to conventional descriptions as "gel-cell" or "lead-acid". If you are unsure about your battery type, consult the manufacturer and use the battery type selector setting which most closely conforms to the recommended voltages. See the SPECIFICATIONS section for the actual preset charge and float voltages for each battery type and charger model.

2) Changing the Switch Setting

As shipped from the factory, the Battery Type Selector Switch has been set in the "Lead-Acid" position. (This switch setting is also the preferred setting for AGM type batteries).

To change the switch setting for gel-cell batteries you must access the charger control board. This is done through an entry panel on the left side of the charger case as shown in the following diagram. (*Note:* Installation of options such as equalization and remote alarms also requires access through this entry panel. For information on the installation of these options, refer to the relevant section elsewhere in this manual.)



Charger Control Board Entry Panel

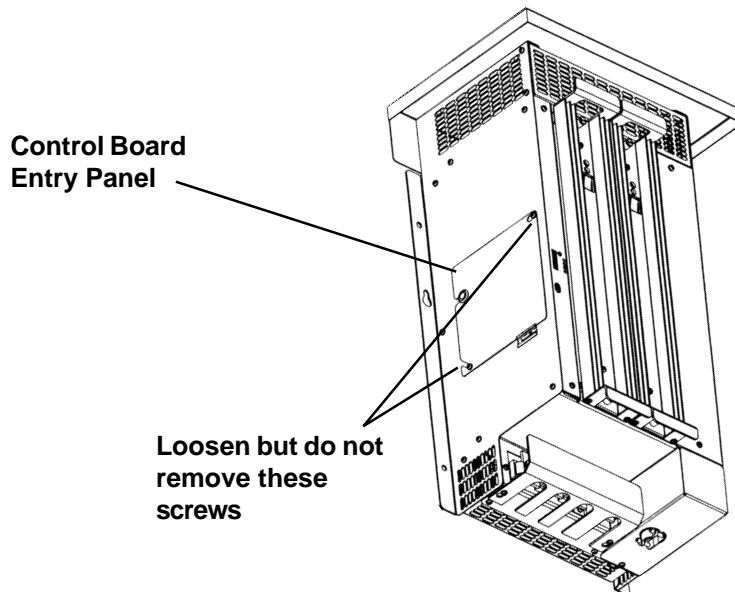

Loosen the retaining screws as shown in the diagram above and remove the entry panel. Locate the black selector switch in silver casing on the control board. Note that below the switch the positions are identified "Gel" and "Lead". Simply slide the switch into the desired position, then replace and secure the entry panel (unless also installing the equalization or remote panel or alarm options—see section IV following).

G) Charger Module Installation/Removal

After all other installation procedures have been completed, apply a.c. power to the PTMC *prior to inserting the PTM modules*. Verify that the red "NO OUTPUT" indicator on the control panel is illuminated. (This indicator should have illuminated as soon as a battery was attached to Bank 1 during the installation.) If so, then it indicates proper battery connection. If it is not illuminated, then it probably indicates a reverse polarity battery connection has blown a fuse on the control board. Check and correct battery connections, if necessary. Replace the 1 amp fuse (access the board as outlined in the previous section). Apply a.c. power again. If the "NO OUTPUT" indicator still does not illuminate, contact the factory.

To complete the installation, ensure the power switch is in the "OFF" position, then slide each PTM module into an open bay. Tighten the top and bottom thumb screws to secure it. Use a slot screwdriver if necessary to secure the screws. Turn the power switch of each module to the "ON" position.

If the PTM System is shipped with only two modules installed there will be a blank panel covering Bay #3. If three modules are installed, the blank panel which is shipped with the charger should be retained for future use. In the event a module must be removed for any length of time, the blank panel should be installed over the unused bay. This will ensure proper air flow of the internal fans and prevent unsafe ingress into the unused bay, a possible shock hazard.

12



(See section V for information on the normal start-up, operation and status indications after the system is operational.) The PTM Charger is designed to allow change-out or addition of modules while the system is up and running, however the power switch on the module itself should be in the "OFF" position prior to insertion or removal.

IV) INSTALLATION OPTIONS

Note: Each of these installation options requires routing of wiring to the control circuit board on the left side of the charger. The gray cable entry on the panel cover is easily cut to provide whatever size hole is necessary to accommodate the wire(s).

A) Remote Monitor Panel Option

A Remote Monitor Panel is available from NEWMAR (model RP-PTM) which will enable you to monitor the charger's status at-a-glance from a remote location. This panel duplicates the diagnostic indications found on the PTMC Status Panel. Refer to section V-C for a complete explanation of these indicators.

The panel comes pre-wired with 30' of cable with six pin modular connector on either end and 4 panel mounting screws. Simply install the panel at the desired location and insert one connector into the panel and the other into the remote panel jack beneath the charger's control board entry panel. The location of the remote panel jack is identified on the panel. *Note:* Inadvertently putting the remote panel plug into the temp compensation jack (or vice versa) will not harm the charger. If the panel does not appear to function correctly, check to see that it is plugged into the correct jack.

If additional cable length is required, additional cable is commonly available from most electronics supply retailers. Request a 6 conductor modular-to-modular line cord.

B) Temperature Compensation Option

Because low battery temperature increases resistance to charging and high battery temperature reduces impedance, requiring a lower charge voltage, the ideal charging voltage will vary depending on the temperature of the battery's environment when it is being charged.

If a charger has a fixed output voltage which is ideal at, say 72° F, that same output may cause a battery charged in a consistently high temperature environment to be over-charged, resulting in excessive loss of electrolyte. Conversely, if the batteries are in a consistently cool environment, they may be chronically undercharged, resulting in sulfation of the battery plates. Either of these two conditions will shorten battery life.

Therefore, the PTM charger is designed to utilize an optional remote sensor (available from NEWMAR; model TCS-12/24) which provides automatic temperature compensation. The remote sensor will signal the charger to fine tune its output voltage so that it is properly matched to the temperature of the battery/battery environment. The adjustment rate is -5 mV per cell per °C (typical). (Note: The temperature compensation option



is strongly recommended for sealed, valve-regulated, AGM or gel-cell batteries.)

The remote sensor is provided with 30' of cable. One end of the cable is plugged into the temperature compensation jack which is located on the charger control board. The location of temp sensor jack is identified on the entry panel.

If additional cable length is required, additional cable is commonly available from most electronics supply retailers. Request a four conductor modular-to-modular line cord.

As there is only one sensor it should be used with the battery which is located where the highest temperature conditions are likely. It may be mounted on the inside of the battery box, or more ideally, directly onto one of the batteries using a clamp or a small amount of silicon-type adhesive. The sensor has a hole in the center which will accommodate a # 6 screw. If you have access to the exterior of a wall of the battery box, you may drill a hole in the wall of the box and run the screw through to mount the sensor onto the interior wall.

Without the temperature sensor installed the output of the charger will be at the nominal voltages specified in the chart on the following page at 77° F (25° C). The absorption/float output voltage settings at that temperature are listed in the chart.

To provide some examples which clarify the effect of the temperature compensation sensor, the chart lists the absorption/float output voltages of the charger when batteries are at 77° F (or when the sensor is not installed), and at cold (50° F) or hot (90° F) battery temperatures with the sensor installed:

Temperature Compensation Chart

Battery Temperature		Output V d.c : 12 Volt Model				Output V d.c : 24 Volt Model			
		Charge		Float		Charge		Float	
° F	° C	Gel	Lead	Gel	Lead	Gel	Lead	Gel	Lead
50	10	14.4	14.6	14.0	13.8	28.8	29.2	28.0	27.6
77	25.0	14.0*	14.2*	13.6*	13.4*	28.0*	28.4*	27.2*	26.8*
90	32.2	13.7	13.9	13.3	13.1	27.4	27.8	26.6	26.2

* Factory pre-set voltages without temperature compensation option installed

To prevent a potentially hazardous battery "thermal runaway" wherein a shorted cell or extreme ambient temperature causes dangerous battery overheating, the PTM charger will automatically shut down when a battery temperature of 50° C (122° F) is sensed. Recovery is automatic once the battery has sufficiently cooled. *A temperature sensor must be installed for this function to operate.*

C) Equalize Timer Option

Some manufacturers of flooded lead-acid batteries recommend a charging process known as equalization for extended battery life. This process involves occasionally charging a wet lead-acid battery at a high voltage for a short period of time in order to completely de-sulphate each of the battery plates, essentially equalizing their voltage. The installer of the PTM charger may choose to wire in this option at the time of installation.

Note: The equalization process is not recommended for sealed valve regulated or gel-cell batteries.

The equalize circuit should be wired through a manual or electric timer which provides a closed contact when engaged and an open circuit when timed out (SPST — Single Pole Single Throw). Do not use a manually operated switch for activating the equalize circuit. This is because unless the charger is reverted to a safe float voltage in a timely manner, the batteries will almost certainly be damaged or destroyed. The timer should be a 0-12 hour type, capable of carrying a minimum of 100 mA at 12V d.c.

CAUTION: Do not install the timer in an area requiring ignition protected equipment unless it has been certified to meet ignition protection requirements.

The equalization circuit of the PTM charger boosts output voltage to approximately 8 % above float voltage. Refer to the battery manufacturer's instructions when deciding the appropriate time period setting for this voltage to achieve proper equalization, while ensuring batteries are not damaged by increased battery temperature. **This installation should only be performed by a qualified technician.**

The terminals for connection of the timer are on the green terminal block J2 which is located on the control circuit board. This is accessed through the control board entry panel. (Refer to previous section III-F for illustration.)

The terminals screw compression type and are rated to 1 amp and 30V d.c. Use 18-22 AWG wire for connecting the timer. Following is a diagram of a typical equalize timer connection:

Typical Equalize Timer Wiring

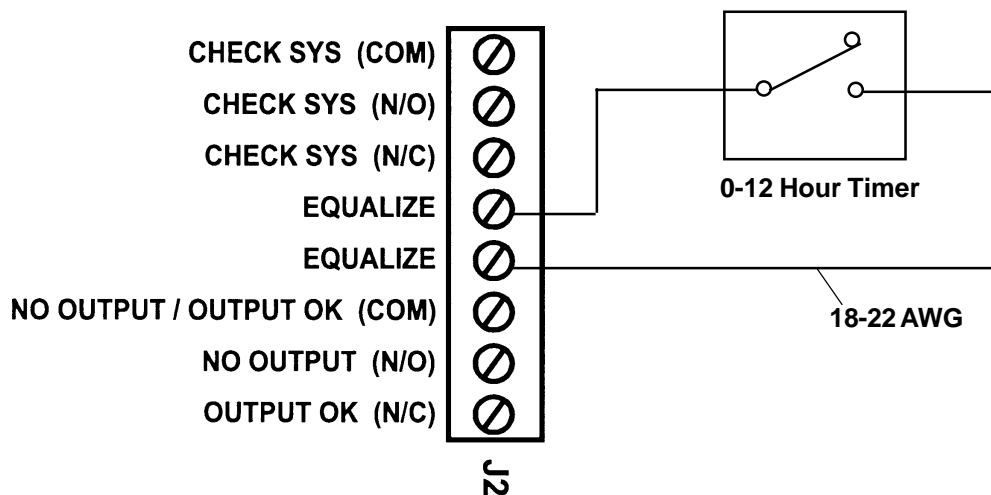

When the timer is activated it provides a "jumper" between the two equalize terminals which in turn activates the higher voltage output required. When it times out the connection is severed and the charger reverts to its safe float voltage.



ELECTRONIC POWER PRODUCTS
COMMUNICATION • NAVIGATION
www.newmarpower.com

15

P.O. Box 1306
Newport Beach,
California 92663

Phone: 714-751-0488
Fax: 714-957-1621
E-Mail: sales@newmarpower.com

D) Remote Alarm Option

The PTM Charger may be wired to trigger a remote visual or audio alarm in the event of any individual module failure using the "Check System" (Warning) remote alarm terminals. Conversely, it may instead be wired to provide indication of continued normal operation.

The remote alarm terminals are located on the same terminal block J2 as cited in the previous section. Following is a typical illustration of wiring a remote indicator/alarm to activate in the event of a module failure:

Typical Check System (Warning) Remote Indicator Wiring

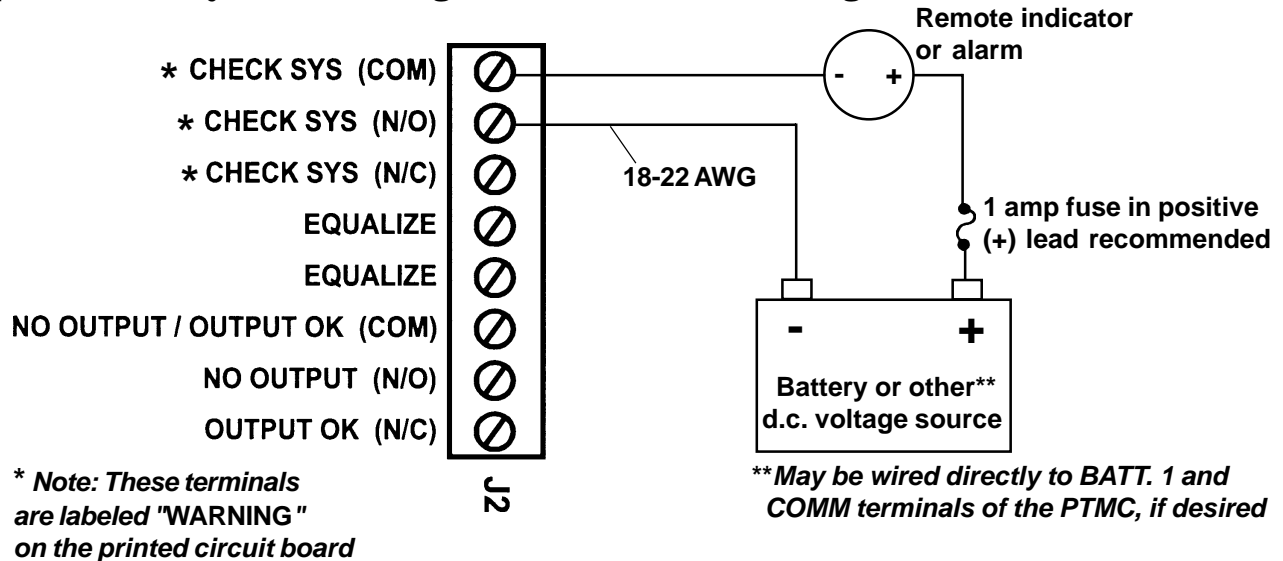

Note that in this example the indicator is wired through the common (COM) and "normally open" (NO) terminals. In this instance the indicator will normally be extinguished. In the event of module failure the internal alarm contacts will change state, completing the circuit and the indicator light will illuminate. If the installer prefers, the indicator may be wired through the common and "normally closed" (NC) terminals. Using this scheme the indicator will remain illuminated to indicate normal operation and will be extinguished only in the case of a module failure.

The PTM may also be wired to activate a remote indicator/alarm in the event of complete system failure or shutdown (as, for instance, during loss of a.c. input to the charger, or temporary auto-shutdown due to over-temperature conditions). This alarm is wired through the "NO OUTPUT/OUTPUT OK" terminals. All of the conditions and recommendations of the above example apply to this installation, as well.

V) OPERATION

A) Three Stage Charge Regimen

The Phase Three Modular Charger utilizes the three stage charge regimen which is

widely recommended by battery manufacturers for allowing the fastest possible recharge time without loss of batteries' electrolyte (gel or liquid) which may be caused by sustained charging at higher voltages.

This three stage regimen is initiated each time a.c. is first applied, when drained batteries are most likely to be encountered, and proceeds slowly or quickly through each stage depending on the battery's relative state of charge.

1) Bulk Phase: When batteries are significantly discharged the charger responds initially by delivering a high amount of d.c. current, at or near the charger's maximum rated output, in order to rapidly replenish them. It is during this stage that charging current is maintained at a high level as battery voltage increases. Bulk charging continues until battery voltage reaches the "charge" voltage level (where batteries are at about 75-80% of capacity). A current limit circuit prevents charger overload during this maximum output stage.

2) Absorption Phase: During this second stage of the charge cycle, battery voltage is maintained at the "charge" voltage level. Output current begins to taper off as the battery plates become saturated. Charge voltage is maintained until the current sensing circuit detects that output current has tapered to about 5-15 % of charger rating*. At this point the batteries are at about 95 % of full charge and the charger switches to the third and final stage of the charge cycle.

* Note: The absorption phase may also be ended by the time-out circuit. See section B following for a complete explanation of the purpose and functioning of this circuit.

3) Float Phase: For extended battery life the charger then automatically switches to a lower float voltage level. This float charge keeps batteries at peak condition without overcharging. The charger may be left in this stage for lengthy periods of time without attention (though periodic checks of electrolyte level in flooded batteries is recommended). It is not necessary or recommended to shut the charger off when this stage is reached.

A typical three stage charging cycle is illustrated below.

Typical Charger Output Graph (into battery without load)

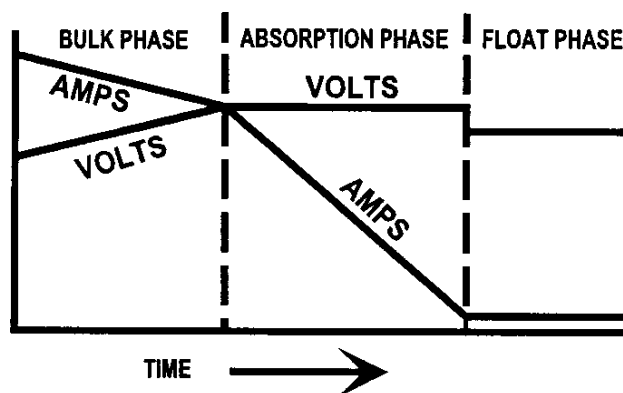

Bulk/Absorption phases last approximately 10 hours maximum at factory setting.

Note: If a load is applied during the absorption phase, the charger may revert to the bulk phase depending on the total current draw. When the charger switches to the float phase, it will remain in that phase regardless of current draw. The charger is still able to deliver full output current when in the float phase. To re-initialize the three stage process shut the charger off momentarily, then back on again.

B) Time-Out Circuit

Batteries have a tendency to lose their electrolyte and may be damaged if they are maintained for long periods of time in the elevated voltage of the absorption phase. Therefore, the PTM Charger employs a special time-out circuit. This circuit is initialized each time a.c. is first applied to the charger and runs for a pre-set interval before forcing the charger to go into the float (lower voltage) mode. The functioning of the charger during this interval is as follows:

If the current demand of the batteries/load falls below 5-15 % of the charger's output capacity prior to the circuit timing-out, the charger will automatically switch to the float mode. If demand rises to about 10-20 % of charger output capacity, it will return to the elevated output voltage of the absorption phase. This switching back and forth between modes may occur until the circuit times-out (8-10 hours after a.c. is first applied), after which the charger will remain at float voltage, until the circuit is re-initialized when the charger has been off and then turned on again.

Installation Note: The time-out circuit of the PT charger has been set at about 8-10 hours, which is appropriate for battery systems within the capacity range specified on the front panel of the charger. If the charger is used with a battery system with a capacity near (or outside) the upper or lower ranges of the specified range of the charger, adjustment of the internally located time-out circuit adjustment pot may be recommended. If it is deemed that the time-out circuit needs adjustment, contact the factory for information on this procedure.

Note: Once the time-out circuit has put the charger into float mode, the charger will remain in this mode as long as a.c. input to the charger remains uninterrupted. Since the Phase Three Charger is well regulated, it is able to deliver its full rated output current in this mode and battery discharge will not occur (provided load current does not exceed charger rating and output wiring is properly sized).

If the user wishes to manually return the charger to the absorption mode for any reason, this is done by simply shutting off a.c. to the charger momentarily, then turning it back on again. This will reset the 8-10 hour timer.

C) PTMC Status/Control Panel

Indicator Lights

The PTM Charger is provided with four status indicator lights to inform the user of both normal and abnormal operating conditions. These function as follows:

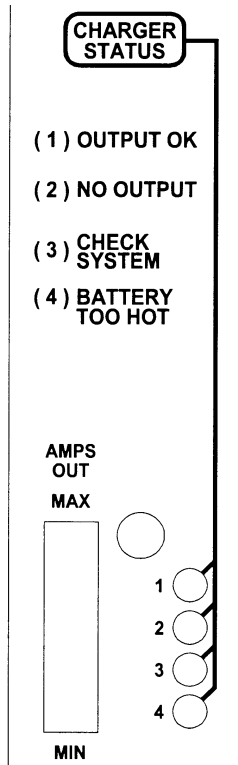

1) OUTPUT OK (GREEN) - Normal operating voltage is available at the output terminals. At least one inserted module is operating normally. If any condition causes a loss of output voltage this light will be extinguished.

2) NO OUTPUT (RED) - There is no output voltage from any inserted module on the output terminals. This may be due to loss of a.c. input, all modules being shut off, or removal or failure (unlikely) of all modules while batteries are still connected.

3) CHECK SYSTEM (ORANGE) - At least one inserted module is not providing proper output voltage. Note: The PTMC detects only modules which are fully inserted, so if a module is not properly inserted or is removed, this light will not be illuminated.

4) BATTERY TOO HOT - The selected heat-sensed battery has over-heated. Because this presents a potentially hazardous situation, the charger has dropped its output voltage to prevent damage from charging a battery in this condition. Note that the temperature compensation sensor must be installed for this indication and protection to occur. (Refer to section IV-B)

L.E.D. Bar Graph Output Amperage Indicator

This provides an indication of the *total* current output of the system. For instance, if half the bars are illuminated, then the charger is putting out about half of total system capacity; if all are illuminated it is at maximum current capacity, etc. *Note: The bar graph is calibrated at the factory according to whether the PTM is configured as a two module or a three module system. If the PTM was shipped from the factory as a two module system and a third module is later added, or conversely, if it was shipped as a three module system and a module is to be removed for any length of time, an internal jumper must be reconfigured for the bar graph to read accurately. Contact the factory for details.* Each bar of the graph represents approximately 10% of the charger's maximum output current capacity.

Output Voltage Test Points

These are provided to allow the installer/technician to measure the exact system output voltage using a portable voltmeter. These test points are connected electrically to the Bank # 1 output terminal.



ELECTRONIC POWER PRODUCTS
COMMUNICATION • NAVIGATION

www.newmarpower.com

19

D) Individual Module Status Indicator

This indicator will glow green whenever the module is putting out normal operating voltage. In the event of failure while the module is still connected, this indicator will glow orange.

G) Cooling Fan

To maximize the life of the internal components and to allow continuous operation at full rating, each individual module employs an integral cooling fan. This fan operates whenever a.c. power is applied to the charger. This fan is not user-serviceable. In the event you suspect fan failure, contact the factory.

The fan operates by drawing cool air through the bottom of the charger and expelling the warmer air out the top. To prevent debris from entering the unit, there is a perforated ventilation cover at the base of the unit. As dust may accumulate on this cover over time, impeding air-flow and diminishing the performance of the fan, periodic cleaning with a moist rag or a vacuum cleaner is strongly recommended.

VI) APPLICATION NOTES

A) Start Up

1) Before powering up the charger, check for tight electrical connections to each battery in your system. Switch off any d.c. loads on the batteries. Switch on all of the PTM Modules. Apply a.c. power. Observe the LED bar graph indicator on the Status/Control Panel.

This meter displays the total d.c. output of the charger, through all banks. It will give some indication of the overall state of charge of your batteries. If the meter is reading mid-scale or higher, it is an indication that the batteries are in a relatively low state of charge. The charger, sensing this, is supplying high current to the batteries. If the meter is at or near the bottom of the scale this indicates the batteries are at or nearing full charge.

2) Apply a load of about 15 amps or more to the charger by switching on some lights, a pump or some other d.c. appliance. Observe the LED bar graph. It should respond immediately to the increased current draw of the appliance. As current is demanded from the battery system, the charger will automatically increase its output in response to the increased load demand. When load current exceeds 10-20 % of the charger's rated capacity, the charger will go into the absorption mode and remain there until current drops below 5-15 % of capacity or until the time-out circuit cycle is complete.

B) Constant Versus Occasional Use

In general, it is recommended that the charger be left connected continuously to the a.c. distribution system so that it will be in operation whenever a.c. is available. This will maintain batteries at peak voltage and will automatically compensate for the natural self-discharge of the battery system. When a load is applied to the battery system the

20



charger's output will automatically increase to supply the current which would otherwise draw battery voltage down. **Repeatedly allowing batteries to become completely discharged before recharging will greatly shorten their life. Leaving the charger on continuously will prevent this.**

While the output regulation of the charger will minimize battery gassing and water loss, monthly checks of the electrolyte level (for wet lead acid batteries) are still strongly recommended. Some water loss is an inevitable aspect of the charging process, and maintaining the correct electrolyte level in your batteries is the most important thing you can do to assure their maximum performance and long life.

C) Proper Load Sizing

The PTM Charger is rated for continuous duty. While the charger cannot be damaged by overloads that exceed this continuous rating, excessive load demands may draw battery voltage down faster than the charger can resupply it. If battery voltage continues to drop and the output current is at maximum while the charger is in service, check to see that your average d.c. loads are not exceeding the charger's rated output. If they are, you may wish to consider adding another module to provide sufficient power for your requirements.

D) Operation With Engine

It is perfectly acceptable to allow the charger to remain on when the engine is started and while it is running. The current limit feature of the Phase Three Charger will protect against any damage due to the high current demands of engine cranking. Output diodes will prevent any back-feed of current into the charger from the alternator while the engine runs.

As the alternator starts to charge the battery, the charger output will decrease. When the battery voltage exceeds the rated output voltage of the charger it will shut off and stay off as long as the batteries are in this high state of charge. If the battery voltage should drop below the charger's rated output voltage it will automatically return to service.

E) Operation as a d.c. Power Supply (stand-alone d.c. power source) or Radar Rectifier

Most battery chargers are not suitable for powering electronic devices directly, without a battery attached to the output, as the high ripple and pulsing d.c. output (i.e., rectified a.c. output) can interfere with the operation of the device. However, this charger employs a circuit that produces an extremely well-filtered d.c. output. Therefore it is able to power virtually any d.c. powered device (within the unit's rating) without the battery attached in-line (if, for instance, the battery must be removed for any purpose and a.c. is still available). All but the most sensitive d.c. powered electronic devices will function as normally as if powered by a battery. In addition, the current limiting circuitry enables the charger to handle the high start-up surges associated with inductive loads, such as d.c. motors in radar sets.



In some rare applications it may be desired that the PTM operate as a stand-alone power supply with a fixed output voltage, rather than the typical battery charging three stage output. This disabling of the three-stage circuit may be accomplished in the field by a jumper reconfiguration on the control circuit board. Contact the factory for more information on this application.

VIII) SPECIFICATIONS

A) PTM Module Specifications

Input Voltage/Frequency: 90-264V a.c., 47-63 Hz, single phase; derate linearly from 100% output @ 105V a.c. to 80% output at 90V a.c.

Power Factor: .96-.99

Input Current @ Full Load: 3 amps @ 230V a.c.; 6 amps @ 115V a.c.

Output Current: PTM-12-40: 40 amps maximum in all phases
 PTM-24-20: 22.5 amps maximum in Bulk phase
 20 amps maximum in Absorption/Float phases

Efficiency: 85 % typical

Regulation: Line: Less than .2 % @ full load from low line to high line
 Load: Less than 2 % from 10 % load to full load

Ripple: Less than 1 % P-P noise and ripple

Nominal Output Voltages (without Temperature Compensation option installed or at 25 °C with Temperature Compensation option installed):

Setting	PTM-12-40		PTM-24-20	
	Charge @ 50 % load	Float @ .5 amp load	Charge @ 50 % load	Float @ .5 amp load
Gel-Cell	14.0V d.c.	13.6V d.c.	28.0V d.c.	27.2V d.c.
Flooded/AGM	14.2V d.c.	13.4V d.c.	28.4V d.c.	26.8V d.c.

Temperature Compensation (with Sensor Installed): - 5 mV per cell per ° C

Temperature Rating: 0-50° C

Recommended Battery Type/Capacity: Gel-Cell, Flooded or Sealed Lead-Acid;

PTM-12-40: 6 cell, 80-400 A-H (per module); 240-1200 A-H (per system)

PTM-24-20: 12 Cell, 40-200 A-H (per module); 120-600 A-H (per system)

Protection Features: Input Fuse, Output Fuse, Current Limiting, Over Voltage Protection, Cooling Fan, Automatic Thermal Shutdown/Recovery

Compliances:

Safety: EN60950-1 USA, Canada, Europe; CE Mark, UL Listed

EMI Radiated and Conducted: FCC Part 15 Level A; EN55022 Class A

Weight: 6 lbs.

B) PTMC Case Specifications

Input Voltage/Frequency: Refer to module specifications

Input Current @ Full Load (with three modules installed):

9 amps @ 230V a.c.

18 amps @ 115V a.c.



Output Current:

PTMC-12X3: 120 amps max

PTMC-24X3: 67.5 amps max

Output Banks: 3

Module Bays: 3

Case Material: Powder Coated Stainless Steel

Weight:

Empty: 16 lbs, 7.3 kg.

With three modules installed: 34 lbs, 15.5 kg.

Case Dimensions (inches):

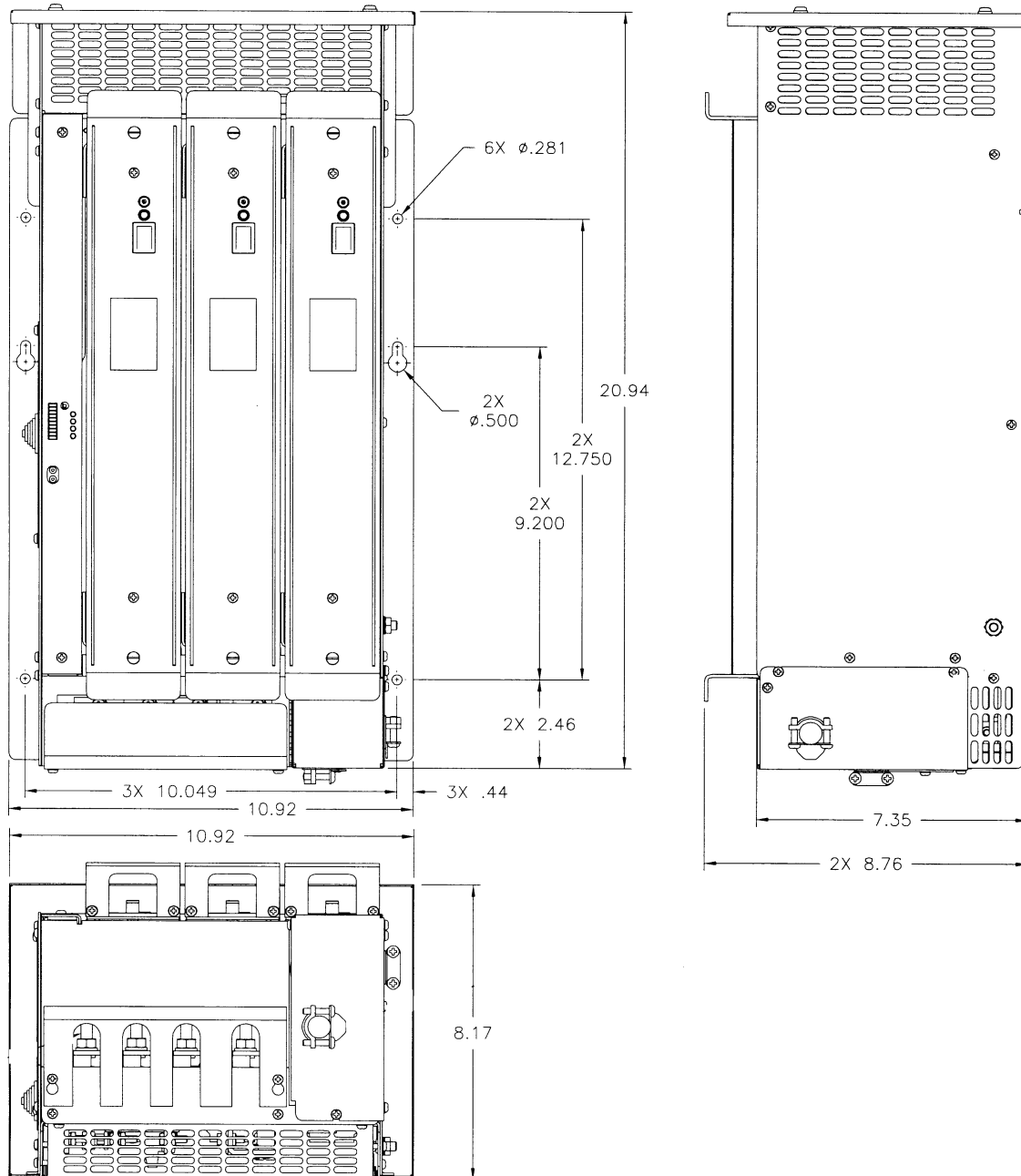

ELECTRONIC POWER PRODUCTS
COMMUNICATION • NAVIGATION
www.newmarpower.com

VIII) BATTERY CARE TIPS

Regular maintenance and proper care will assure you reliable service from the most depended upon and sometimes most neglected items, your batteries and battery charger. NEWMAR battery chargers are designed to keep your batteries fully charged but your batteries also need proper regular maintenance to provide a maximum life of service.

ALWAYS READ AND FOLLOW THE BATTERY MANUFACTURER'S INSTRUCTIONS

Battery Installation

Batteries must be securely mounted to prevent them from falling over when the vehicle or boat is in motion. A loose battery can do serious damage. Batteries should be mounted in a battery box to contain any acid spill. Batteries give off a certain amount of hydrogen gas when they are charging. When concentrated, this gas is highly explosive. Therefore make sure they are in an accessible place with adequate ventilation for any hydrogen gas discharge.

Cleaning Batteries

Dirt and electrolyte salts can build up on the top of your batteries. This accumulation conducts electricity stored in the battery and can cause the battery to discharge by itself. Therefore, at least twice a year, it is a good idea to disconnect the battery cables and scrub the battery with a baking soda solution. Rinse with fresh water and dry with a clean cloth.

You may wish to purchase a set of terminal post corrosion prevention rings. These are alkali-saturated felt rings that slip over the battery post to reduce corrosion. Do not apply grease to any part of the battery terminals, but you may use an occasional light spray of silicone lubricant.

Routine Checks and Maintenance

Batteries should periodically be "exercised" (slowly discharged and then recharged) to keep them in top condition. New batteries may need to be exercised before they will be capable of their full rating.

If your batteries are not the sealed type, distilled water should be added to them whenever needed. The electrolyte should cover the plates by about 1/2", allowing a small air space at the top. Do not fill the cells up to the filler cap as this could cause the battery to sputter out electrolyte when it is being charged. Only distilled water should be used never plain tap water. Tap water contains chemicals and elements that can alter the properties of the electrolyte, including specific gravity. Some chemicals may also create an insulating coating on the battery plates which will retard current flow.

The rate that water is lost by the battery is dependent on several factors; battery

condition, ambient temperature, battery use, charge voltage, etc. It is normal for batteries which are not maintenance-free to require topping off about once a month.

A battery's state of charge may be monitored by checking the specific gravity or by open circuit voltage. You may use the following table to evaluate the condition of your batteries:

Battery Condition Table

Specific Gravity Measured by Hydrometer	Open Circuit Voltage		State of Discharge @ 80° F
	12 Volt System	24 Volt System	
1.265	12.6 or more	25.2 or more	Fully Charged
1.225	12.4	24.8	25 % Discharged
1.190	12.2	24.4	50 % Discharged
1.155	12.0	24.0	75 % Discharged
1.120	11.7 or less	23.4 or less	100 % Discharged

** Note: Wait at least 5 minutes after charging or discharging before checking specific gravity or open circuit voltage. The battery's voltage needs to stabilize in order to get an accurate reading.*

Troubleshooting Your Battery System

If your battery will not accept or hold a charge, one of the following conditions may exist:

1. **A BAD BATTERY.** You may have a battery with an open or shorted cell, a battery without any "life" left. Check by charging the battery until all cells have a specific gravity of 1.225 or greater at 80° F. If you are unable to obtain 1.225 in each cell, replace the battery.

2. **A BAD BATTERY CHARGER.** If the battery open circuit voltage is low and/or the hydrometer indicates your batteries are low, the battery charger should be providing current to the batteries. If it is not, check the input fuse and check to see that you have charging voltage on the output with no battery attached. *Note: You will not get an accurate voltage reading on the output of the charger with no batteries attached. This is checked merely to ensure that you do not have an open circuit on the output.*

The battery charger has a thermal power reduction circuit to protect the charger from overheating. If you suspect this is the case, refer to the INSTALLATION section for information about proper charger location.

3. **ELECTRICAL LEAKAGE.** You may have a previously unsuspected source of

current drain from the battery. To check for a leakage of this sort, disconnect the battery ground cable and connect an ammeter between the negative battery post and ground. If you have a reading over .1 amp, there is a source of current drain from the batteries which must be located and removed.

IX) REFERENCE APPENDIX

* For more information about boat wiring to conform to U.S. Coast Guard regulations, write:

Superintendent of Documents
Government Printing Office
Washington, DC 20402

Request : 33 CFR 183 Subpart I

* For information about American Boat and Yacht Council recommendations for boat wiring, write to:

American Boat and Yacht Council
3069 Soloman's Island Road
Edgewater, MD 21037

Request: Standards and Recommended Practices for Small Craft.
AC systems: Section E8
DC systems: Section E9

* For additional installation instructions, refer to:
ANSI NFPA 302